

PRESET PROGRAMS



This processor is ready programmed with the following (variable) settings.
 To return to these settings at any time:
 Power off the processor, press **TIME** key and keep it pressed giving power on:
 release **TIME** key when on the screen appear *boot* message.
t.on = 10" **t.oF = 20"**
 The **COST** values are shown in **COST** paragraphs.

HP19

SL 3.2
Multi-Timer

Handbook

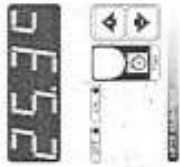

"HAND MODE"



In some start-up conditions may be useful to work in "hand" mode.
 Power off the processor, press + key and keep it pressed giving power on:
HAnd message will be displayed (release now + key)
 Push + (1 is displayed) and push **TIME** for activating relay.
 You can press **TIME** for a least two seconds to escape and return to the *Run Mode*.

INSTALLATION

How to connect the line
 Connect line on terminals **L-N**.
 Protect supply with adequate fuses.

How to connect the contacts
 Connect terminals **3-4-5** on the terminal block (contacts up to **4AMP.AC1**).

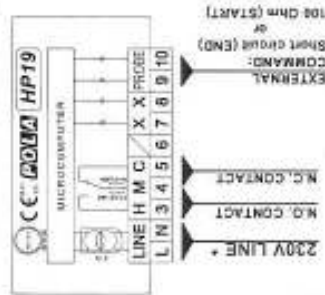

* Other power voltage if you required

MAIN SETTINGS (Run mode)

TIMES SETTINGS

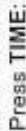

Press **TIME**:
 This message will be displayed instead of the
Set On Time (not if **TYPE=3, TYPE=6**).
 Press + 0 - to modify, press **TIME** to confirm.

At this point: this message will be displayed instead of the
Set Off Time (not if **TYPE=4, TYPE=5**).
 Press + 0 - to modify, press **TIME** to confirm.

In normal operating conditions is displayed elapsed time or
 count-down time (see function **Cntd**).

Measurement unit is established by function **UnitE**.

9.9"1	10"1	9.9"1	10"1	12.34
ME=1 : SSS.0 Seconds with decimal Setting 0.0...999.9*	ME=2 : SSSS Seconds Setting 0"...9999*	ME=3 : MM.MD Minutes with decimal Setting 0.0...999.9*	ME=4 : MM.MM Minutes Setting 0...9999*	ME=5 : MM.SS Minutes seconds Setting 0"...99"

As a company policy to continually improve the products the Manufactureres reserve the right to make any modifications here and without prior notice. They cannot be held liable for any damage due to malfunction.



19 07 06

COSI PROGRAMMING (System constants)



These settings refer to the mode operation of the system and must be made on initial start-up.
Press - / + together for at least one second; the message **C.O.S.t.** will be displayed.

Press then repeatedly **TIME** until interested variable's message is displayed (see table below) ; variable value and related message will be displayed.

Press * or - to set a new value and then **TIME** to confirm.
The next system constant will then appear.

You can press **TIME** for a least two second to escape and return to the *Run Mode*.

Mess.	Value	Meaning	Note
time	=2	Base time unit	*1
cntd	=0	=0: display count-up. =1: display count-down	
type	=1	Working mode	*2
LOGO	=1	=0: power-on>works. =1: LOGO: HP19; SL3.2; PASS (2 sec)	
SECU	=0	=0: NORMAL. =1: keys command and setting inhibited	
t.on	10"	As Timer key set (needed if SECU=1)	
t.oF	20"	As Timer key set (needed if SECU=1)	
n.PLS	=1	Number of pulses (only for TYPE9) range 1...99	

*1) time : Base time unit

- =1 : Seconds with decimal
- =2 : Seconds
- =3 : Minutes with decimal
- =4 : Minutes
- =5 : Minutes with seconds

*2) type : Working mode (see WORKING MODES DESCRIPTION DIAGRAM)

- =1 : Cycler off-on
- =2 : Cycler on-off
- =3 : Delay off
- =4 : Delay on
- =5 : Impulse on
- =6 : Impulse off
- =7 : Delayed impulse on
- =8 : Delayed impulse off
- =9 : n.PULSES STRING

WORKING MODES DESCRIPTION DIAGRAM (TYPE)

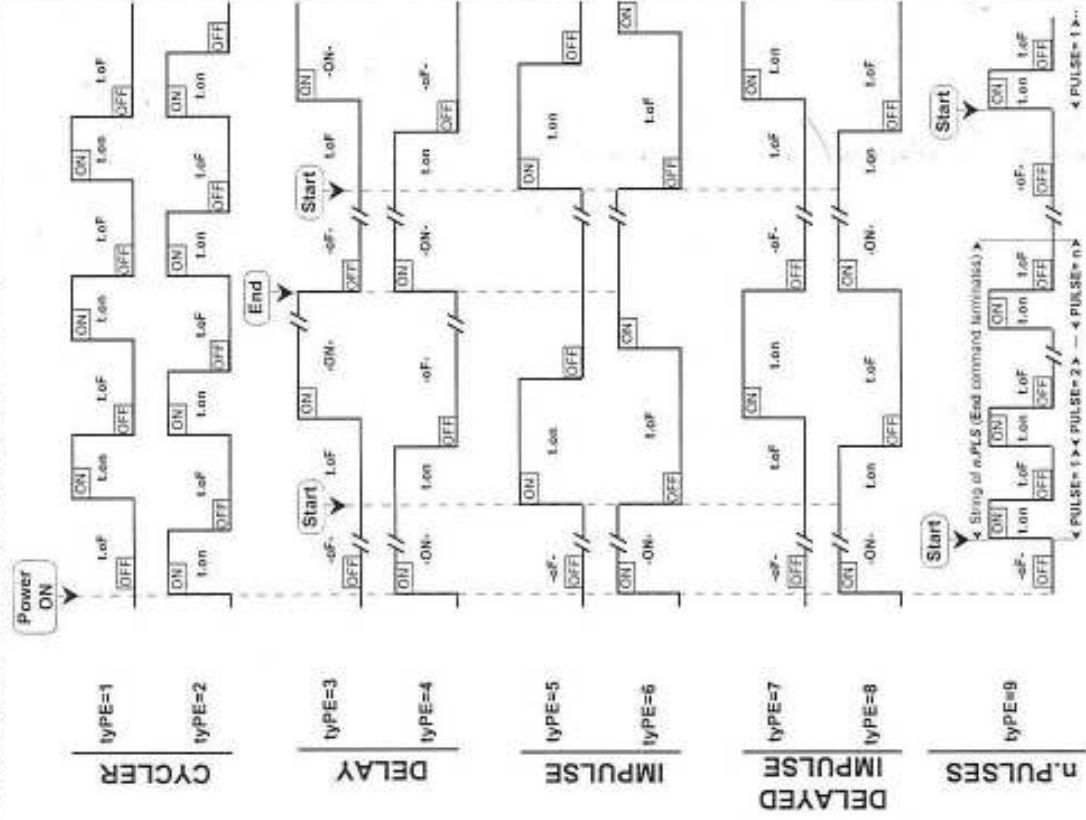

Available commands xx (contacts 7-8) S.C.= bridge or 100ohm optional resistor.

CYCLER : xx = S.C. > -oF- ; xx = 100ohm > -ON- (no keys command)

OTHERS : xx = 100ohm or key > Start ; xx = S.C. or key > End