

Thermometers and temperature electronic controllers

Devices designed to display, control and regulate cooling generators (manual or automatic programmable defrosting by stopping the compressor) or heating generators.

1- Versions and References

MODEL	FUNCTION	RELAY 250 V, cos $\varphi=1$	POWER SUPPLY, 50/60 Hz
AKO-14012	Thermometer	-	12/24 V~/= $\pm 20\%$
AKO-14023	Thermometer	-	230 V~ $\pm 10\%$
AKO-14112	Controller	16 A (13 (4) A s/EN-60730-1), SPDT	12/24 V~/= $\pm 20\%$
AKO-14120	Controller	16 A (13 (4) A s/EN-60730-1), SPDT	120 V~ +8% / -12%
AKO-14123	Controller	16 A (13 (4) A s/EN-60730-1), SPDT	230 V~ $\pm 10\%$
AKO-14125	Controller	16 A (13 (4) A s/EN-60730-1), SPDT	230 V~ $\pm 10\%$
AKO-14129	Controller	30 A (18 (5) A s/EN-60730-1), SPST	230 V~ $\pm 10\%$
AKO-14139	Controller	30 A (18 (5) A s/EN-60730-1), SPST	120 V~ +8% / -12%

2- Technical data

Temperature range according to type of sensor configured:
 NTC -50.0 °C to 99.9 °C (-58.0 °F to 211 °F)
 PTC -50.0 °C to 150 °C (-58.0 °F to 302 °F)
 Resolution, Set Point and differential: 0,1 or 1 °C/°F configurable by parameter P7
 Input for probe:
 NTC AKO-149XX
 PTC AKO-1558XX
 Thermometric accuracy: ± 1 °C
 Probe tolerance at 25 °C:
 NTC $\pm 0,4$ °C
 PTC $\pm 1,25$ °C
 Maximum input power: 3 VA
 Working ambient temperature: 5 °C to 50 °C
 Storage ambient temperature: -30 °C to 70 °C
 Control device classification:
 Independent mounting, with characteristic of automatic operation Type 1.B action, to be used in a clean situation, logical medium (software) class A and continuous operation. Degree of contamination 2 on UNE-EN 60730-1
 Double insulation between the power supply, the secondary circuit and the relay output.
 Allocated pulse temperature: 2500 V
 Pressure ball test temperature:
 Accessible parts: 75 °C
 Parts that position active elements: 125 °C
 Voltage and current declared by the EMC tests: AKO-14012: 9.6 V~, 88 mA~
 AKO-14023: 207 V~, 8 mA~
 AKO-14112: 9.6 V~, 182 mA~
 AKO-14120: 105 V~, 30 mA~
 AKO-14123: 207 V, 9 mA~
 AKO-14129: 207 V, 13 mA~
 AKO-14139: 105 V~, 34 mA~
 Current of radio jamming suppression test: 270 mA~

3- Installation

The controller should be installed in a place protected from vibrations, water and corrosive gases, and where ambient temperature does not surpass the value specified in the technical data. In order the controllers be suitable having IP65 protection, the gasket should be installed properly between the apparatus and the perimeter of the panel cut-out where it is to be fitted. In order to give a correct reading, the probe should be installed in a place without heat influences other than the temperature that is to be measured or controlled.

3.1 Fastening:

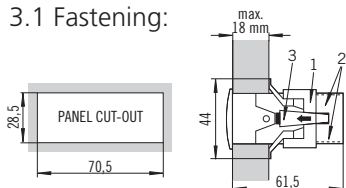

To fix the unit, place the fasteners 1 over the sliders 2 as shown in the figure. Move the fasteners in the direction of the arrow. By pressing tab 3 fasteners may be moved in the opposite direction of the arrow.

3.2 Connection:

The probe and its lead should NEVER be installed in ducting along with power, control or power supply wiring.
 The power supply circuit should be connected with a minimum 2 A, 230 V, switch located close to the unit. Power supply cables should be H05VV-F 2x0,5 mm² or H05V-K 2x0,5 mm². Section of connecting wires for relays contacts should be 2,5 mm².
 AKO-14129, AKO-14139: Relay contact wires should be H07V2 or H07Z 2,5 mm².

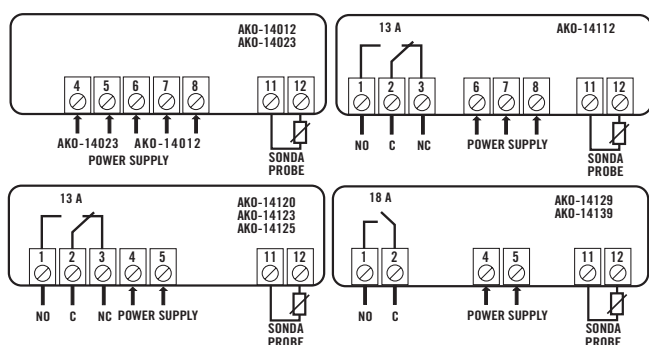

4- Front Panel Functions

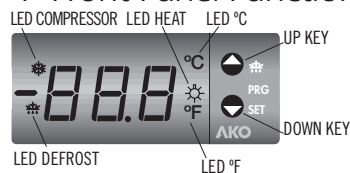

LED Compressor (Controllers function).
Permanent: Relay (compressor) energised if control operates in cold.
Flashing: Because of the temperature detected by Sensor, the Compressor relay should be energised, but is no due to a programmed parameter.

LED Heat (Controllers function).

Permanent: Relay energised if control operates in heat.

Flashing: Because of the temperature detected by Sensor, the relay should be energised,

LED Defrost (Controllers function).

Permanent: Indicates defrost in operation.

LED °C

Permanent: Degrees °C indicator.

Flashing: Programming phase.

LED °F

Permanent: Degrees °F indicator.

Flashing: Programming phase.

UP KEY

- In programming, it makes the displayed value increase.

- When pressed for at least 5 seconds, a manual defrost is started with programmed duration. (Controllers function).

DOWN KEY

- In programming, it makes the displayed value reduce.

- When pressed for at least 5 seconds, the SP Set Point temperature is displayed. (Controllers function).

5- Adjustment and Configuration

It should only be programmed or modified by personnel who are fully conversant with the equipment operation and possibilities.

5.1 Set point temperature

The factory SET POINT default value is 0.0 °C.

- Press key for at least 5 seconds to DISPLAY SET POINT. It displays the CURRENT SET POINT value and LED °C or °F starts flashing.

- Press or keys to CHANGE SET POINT into the required value.

- Pressing + keys simultaneously to ACCEPT THE NEW SET POINT. The display returns to the CURRENT TEMPERATURE display status and LED °C or °F stops flashing. When PA is displayed, PASSWORD programmed in L5 parameter of tid menu should be entered to access the CURRENT SET POINT.

- Press + keys simultaneously. 0 will be displayed to ENTER PASSWORD.

- Press or keys to CHANGE NUMBER and DISPLAY PASSWORD programmed.

- Press + keys simultaneously to ACCEPT PASSWORD. The CURRENT SET POINT value will be displayed and it can be already modified.

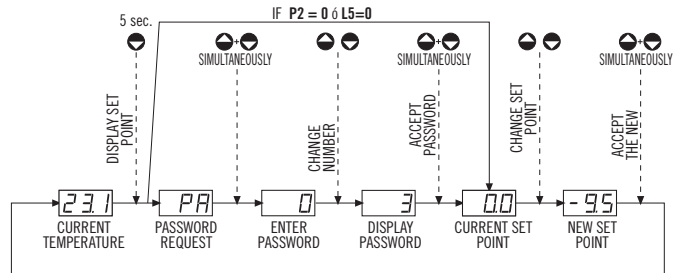

5.2 Parameters configuration

Level 1 Menus

- Press simultaneously + keys for at least 10 seconds. LED °C or °F will be flashing, we are in the programming LEVEL 1 MENU and the first menu "re" is displayed.
 - Press key to access the next menu and key to return to previous one.

- Pressing + keys simultaneously in the last parameter EP, the controller returns to the CURRENT TEMPERATURE display status and LED °C or °F will stop flashing. When PA is displayed, PASSWORD programmed in L5 of "tid" menu should be entered to access programming LEVEL 1 MENU.

- Press + keys simultaneously. 0 will be displayed to ENTER PASSWORD.

- Press or keys to CHANGE NUMBER and DISPLAY PASSWORD programmed.

- Press + keys simultaneously to ACCEPT PASSWORD. The first menu "re" will be displayed.

Level 2 Parameters

- In the desired menu of LEVEL 1 MENU, press + keys simultaneously. LEVEL 2 PARAMETERS programming is accessed. The first parameter of the selected menu is displayed on the screen.

- Press key to access the next parameter and key to return to the previous one.

- Pressing + keys simultaneously in the last parameter EP, the controller returns to the LEVEL 1 MENU.

Level 3 Values

- To DISPLAY the CURRENT VALUE of any parameter, select the required one and press + keys simultaneously. Once it is displayed, you can CHANGE VALUE, pressing or key.

- Press + keys simultaneously to ACCEPT THE NEW. The programming returns to LEVEL 2 PARAMETERS.

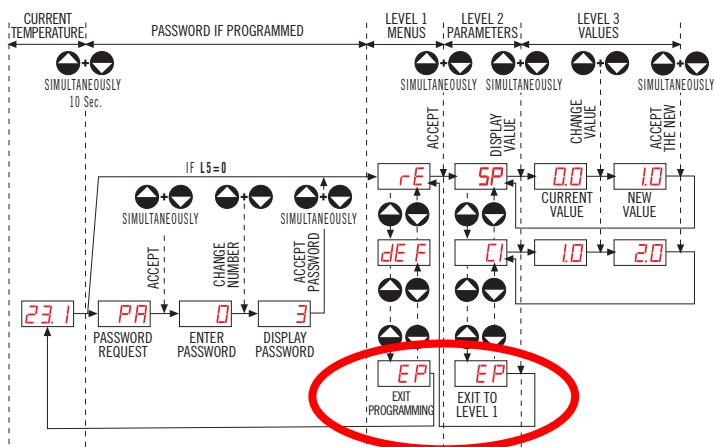

REMARK: If no key is pressed for 25 seconds in either of the previous steps, the controller will automatically return to the CURRENT TEMPERATURE display status without modifying any of the parameters values.

6- Description of parameters and messages

Values in the Def. column are factory-set.

AKO-14012, AKO-14023					
AKO-14112, AKO-14120, AKO-14123, AKO-14125, AKO-14129, AKO-14139					
Level 1 Menus and Description					
rE	Level 2	Control	Description	Values	Min. Def. Max.
SP	Level 3	Set Point temperature	(°C/°F)	-58.0 0.0 350	•
C0	Level 3	Sensor calibration (Offset)	(°C/°F)	-20.0 0.0 20.0	• •
C1	Level 3	Sensor differential (Hysteresis)	(°C/°F)	0.1 2.0 20.0	• •
C2	Level 3	Set Point upper limit (It cannot be set above this value)	(°C/°F)	C3 99.9 350	• •
C3	Level 3	Set Point lower limit (It cannot be set below this value)	(°C/°F)	-58.0 -50.0 C2	• •
C4	Level 3	Relay protection delay type: 0=OFF/ON (From the last switch-off) 1=ON (At switch-on)		0 0 1	• •
C5	Level 3	Protection delay time (Value for the option selected in parameter C4)	(min.)	0 0 255	• •
C7	Level 3	Relay time in ON in case of faulty sensor (If C7=0 and C8≠0, the relay will always be OFF disconnected)	(min.)	0 10 255	• •
C8	Level 3	Relay time in OFF in case of faulty sensor (If C8=0 and C7≠0, the relay will always be ON connected)	(min.)	0 5 255	• •
dEF	Level 2	DEFROST control (if P0=0 Direct, Cold)			
d0	Level 3	Defrost frequency (Elapsed time between 2 starts)	(h.)	0 6 120	•
d1	Level 3	Defrost maximum duration	(min.)	0 30 255	•
d2	Level 3	Type of message during defrost: (0=Current temperature display) (1=Defrost start temperature display) (2=Display dEF message)		0 2 2	•
d3	Level 3	Message maximum duration (Time added at the end of defrost)	(min.)	0 5 255	•
CnF	Level 2	GENERAL STATUS			
P0	Level 3	Type of operation (0 = Direct, Cold) (1 = Reverse, Heat)		0 0 1	•
P1	Level 3	Delay of all functions on power supply switch on	(min.)	0 0 255	•
P2	Level 3	Allocation of password to Set Point: (0=Without allocation) (1=With allocation of L5 password)		0 0 1	•
P3	Level 3	Initial parameters: (1=YES, configure to "Def" and exit programming)		0 0 1	• •
P5	Level 3	Address for units with communication		0 1 255	• •
P7	Level 3	Temperature display mode: (0=Integers in °C) (1=One decimal in °C) (2=Integers in °F) (3=One decimal in °F)		0 1 3	• •
P9	Level 3	Sensor type selection: (0=NTC) (1=PTC)		0 0 1	• •
tid	Level 2	ACCESS AND INFORMATION control			
L5	Level 3	Access password to parameters and information		0 0 99	• •
L6	Level 3	Parameters transfer: (0=Disabled) (1=Send) (2=Receive)		0 0 2	• •
PU	Level 3	Program version (Information)			• •
Pr	Level 3	Program revision (Information)			• •

REMARK: When time parameters are modified, the new values are applied when the current cycle is completed. In order for it to have an immediate effect, switch the controller off and then on again.

MESSAGES	
PA	Password request to enter programming parameters or SET POINT
dEF	It indicates defrosting is being carried out. In order to display "dEF" during defrosting, it is essential that parameter d2 is set to option 2.
CPY	Parameters received from the parameters server.
E1	Sensor failure (Open circuit, crossed, NTC: temp.> 110°C or temp.<-55°C PTC: temp.> 150°C or temp.<-58°C)
EEE	Memory failure

7- Parameters transfer

Portable server

AKO-14918 portable server, with no power supply, in which parameters programmed in a powered controller can be copied by transfer. Parameters can be transferred again from the server to other identical powered controllers.

Storage dump or fast copy of the parameters entered in the portable server to the controller: Press the key while the controller is being connected to the power supply until the display shows **CPY**, indicating that the transfer was made correctly. Disconnect the controller and reconnect it to the power supply. Storage dump can also be done from parameter L6=2.

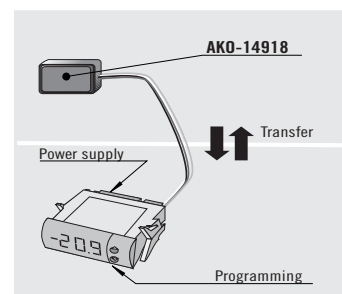

8- Relay operation and control

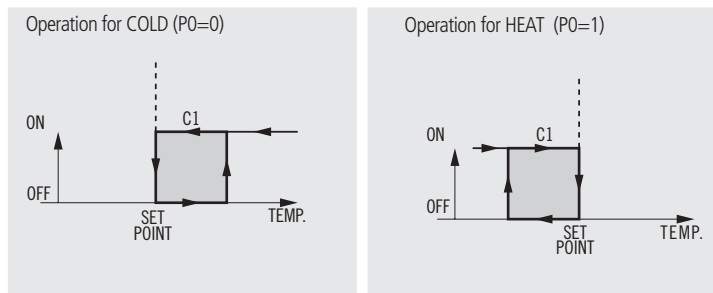

9-Maintenance

Clean the controller surface with a soft cloth, soap and water. Do not use abrasive detergents, petrol, alcohol or solvents.

10-Warnings

The use of the unit without observing the manufacturer's instructions may alter its safety qualification. To ensure correct operation of the apparatus, only NTC or PTC type probes supplied by AKO should be used. Between -40 °C and +20 °C, when the NTC probe is extended up to 1.000 m with minimum 0,5 mm² cable, deviation will be less than 0.25 °C (Probe extension cable ref. **AKO-15586**).